



## Operating Manual

Industrial pressure transmitter DMK / DMP, screw-in transmitter LMK / LMP for IS-areas  
**DX4-DMK 351, DX4-DMK 351P, DX4-LMK 351, DX4B-DMK 387,**  
**DX9-DMK 331, DX9-DMK 331P, DX9-DMP 311, DX9-DMP 321, DX9-DMP 331, DX9-DMP 331i, DX9-DMP 331P, DX9-DMP 331Pi, DX9-DMP 333, DX9-DMP 333i, DX9-DMP 334, DX9-DMP 335, DX9-DMP 339, DX9-DMP341, DX9-DMP 343, DX9-LMK 331, DX9-LMP 331, DX9-LMP 331i, DX9-17.600G, DX9-17.605G, DX9-26.600G**  
**DX10-DMP 331, DX10-DMP 331i, DX10-DMP 333, DX10-DMP 333i, DX10-LMP 331, DX10-LMP 331i**



BA\_DMU-ES\_EX\_E\_SRO [www.bdsensors.cz](http://www.bdsensors.cz)

**Headquarters Eastern Europe**  
 BD SENSORS s.r.o.  
 Hradištská 817  
 CZ - 687 08 Buchlovce  
 Czech Republic  
 Tel.: +42 (0) 572-4110 11  
 Fax: +42 (0) 572-4114 97

**Headquarters Western Europe**  
 BD SENSORS GmbH  
 BD-Sensors-Str. 1  
 D - 95199 Thierstein  
 Germany  
 Tel.: +49 (0) 9235-9811-0  
 Fax: +49 (0) 9235-9811-11

### further agencies in:

EUROPE	ASIA	AFRICA	AUSTRALIA
<ul style="list-style-type: none"> <li>Belgium</li> <li>Denmark</li> <li>Finland</li> <li>France</li> <li>Great Britain</li> <li>Greece</li> <li>Italy</li> <li>Lithuania</li> <li>Luxemburg</li> <li>Netherlands</li> <li>Norway</li> <li>Poland</li> <li>Portugal</li> </ul>	<ul style="list-style-type: none"> <li>Romania</li> <li>Sweden</li> <li>Switzerland</li> <li>Israel</li> <li>Slovakia</li> <li>Spain</li> <li>Turkey</li> <li>UK</li> <li>Ukraine</li> <li>India</li> <li>Iran</li> <li>Malaysia</li> <li>Japan</li> <li>Kazakhstan</li> <li>Singapore</li> <li>Taiwan</li> <li>Thailand</li> <li>Vietnam</li> </ul>	<ul style="list-style-type: none"> <li>Egypt</li> <li>South Africa</li> </ul>	

The addresses of our distribution partners are listed on our homepage [www.bdsensors.com](http://www.bdsensors.com). It is possible to download data sheets, operating manuals, ordering codes and certificates, as well.

### Table of contents

1. General information
2. Product identification
3. Mechanical installation
4. Special regulations for IS-Areas
5. Electrical Installation
6. Initial start-up
7. Placing out of service
8. Maintenance
9. Service / Repair
10. Disposal
11. Warranty conditions
12. Error handling
13. Declaration of conformity / CE

## 1. General information

### 1.1 Information on the operating manual

This operating manual contains important information on proper usage of the device. Read this operating manual carefully before installing and starting up the pressure measuring device.

Adhere to the safety notes and operating instructions which are given in the operating manual. Additionally applicable regulations regarding occupational safety, accident prevention as well as national installation standards and engineering rules must be complied with!

For the installation, maintenance and cleaning of the device, you must absolutely observe the relevant regulations and stipulations on explosion protection (VDE 0160, VDE 0165 or EN 60079-14) as well as the occupational safety provisions. The device was constructed acc. to standards EN 60079-0:2012 as amended, EN 60079-11:2012 as amended, EN 60079-26:2015 as amended.

This operating manual is part of the device, must be kept nearest its location, always accessible to all employees.

This operating manual is copyrighted. The contents of this operating manual reflect the version available at the time of printing. It has been issued to our best knowledge. However, errors may have occurred. BD SENSORS is not liable for any incorrect statements and their effects.

– Technical modifications reserved –

### 1.2 Symbols used

- ⚠ DANGER! – dangerous situation, which may result in death or serious injuries
- ⚠ WARNING! – potentially dangerous situation, which may result in death or serious injuries
- ⚠ CAUTION! – potentially dangerous situation, which may result in minor injuries
- ⚠ CAUTION! – potentially dangerous situation, which may result in physical damage
- 📖 NOTE – tips and information to ensure a failure-free operation

### 1.3 Target group

⚠ WARNING! To avoid operator hazards and damages of the device, the following instructions have to be worked out by qualified technical personnel.

### 1.4 Limitation of liability

By non-observance of the operating manual, inappropriate use, modification or damage, no liability is assumed and warranty claims will be excluded.

### 1.5 Intended use

- The **pressure transmitters DMK/DMP** have, according to the type, been developed for applications in overpressure and vacuum as well as for absolute pressure measurement. The **screw-in transmitters LMK/LMP** have been particularly developed for level and process measurement.
- This operating manual applies to devices with explosion protection approval and is intended for the use in IS-areas. A device has an explosion protection approval if this has been specified in the purchase order and confirmed in our order confirmation. In addition, the manufacturing label contains the Ⓢ-symbol.
- It is the operator's responsibility to check and verify the suitability of the device for the intended application. If any doubts remain, please contact our sales department in order to ensure proper usage. BD SENSORS is not liable for any incorrect selections and their effects!

Permissible media are gases or liquids, which are compatible with the media wetted parts described in the data sheet. In addition it has to be ensured, that this medium is compatible with the media wetted parts.

The technical data listed in the current data sheet are engaging. If the data sheet is not available, please order or download it from our homepage. (<http://www.bdsensors.com>)

⚠ WARNING! Danger through improper usage!

### 1.6 Safety description

Depending on the type of the device, different approvals are valid. The designation of the approval (DX3, DX4, DX4A, DX5, DX5A or DX9) to match up with the following values is written on the manufacturing label under type designation. Permissible temperatures of environment are specified in the current data sheet.

#### 1.6.1. Marking, limit values, temperature range:

**DX4-DMK 351, DX4-DMK 351P, DX4-LMK 351**

Ex marking:

- Ⓢ II 1G Ex ia IIC or IIB T6 or T4 Ga
- Ⓢ II 1D Ex ia IIIC T110 °C Da

Ui = 28 V; Ii = 93 mA; Pi = 660 mW; Ci = 14 nF, Li = negligible, plus the power supply connection has an internal capacity of max. 27 nF between the live parts and the housing plus cable inductivities 1.5 µH/m and cable capacities 220 pF/m (for cable by factory)

Permissible temperatures for environment:

application in zone 0:  
 (P<sub>atm</sub> 0.8 bar up to 1.1 bar): -20 ... 60 °C  
 application in zone 1: -25 ... 70 °C  
 for T6: -25 ... 60 °C (DMK 351)

Certificate Number:  
 IBEU05ATEX1069 X

#### DX4B-DMK 387

Ex marking:

- Ⓢ II 1G Ex ia IIC T4 Ga (metal case)
- Ⓢ II 2G Ex ia IIC T4 Gb (plastic case)
- Ⓢ II 1D Ex ia IIIC T135 °C Da

Ui = 28 V; Ii = 93 mA; Pi = 660 mW; Ci = 14 nF, Li ≈ 0 µH, the supply connections have an inner capacity of max. 27 nF to the housing plus cable inductivities 1 µH/m and cable capacities 160 pF/m (for cable by factory)

Certificate Number:  
 IBEU15ATEX1067 X

**DX9-DMK 331, DX9-DMK 331P, DX9-DMP 311, DX9-DMP 321, DX9-DMP 331, DX9-DMP 331i, DX9-DMP 331P, DX9-DMP 331Pi, DX9-DMP 333, DX9-DMP 333i, DX9-DMP 334, DX9-DMP 335, DX9-DMP 339, DX9-DMP341, DX9-DMP 343, DX9-LMK 331, DX9-LMP 331, DX9-LMP 331i, DX9-17.600G, DX9-17.605G, DX9-26.600G**

Ex marking:

- Ⓢ II 1G Ex ia IIC T4 Ga
- Ⓢ II 1D Ex ia IIIC T135 °C Da
- Ⓢ II 2D Ex ia IIIC T85 °C Db

Ui = 28 V; Ii = 93 mA; Pi = 660 mW; Ci ≈ 0 nF, Li ≈ 0 µH, the supply connections have an inner capacity of max. 27 nF to the housing plus cable inductivities 1 µH/m and cable capacities 160 pF/m (for cable by factory)

Permissible temperatures for environment:

zone 0 (P<sub>atm</sub> 0.8 bar up to 1.1 bar): -20 ... 60 °C  
 zone1, zone2: -40 °C / -20 °C ... 70 °C  
 precision nstrument (i): -40 °C / -20 °C ... 65 °C

Certificate Number:  
 IBEU10ATEX1122 X

**DX10-DMP 331, DX10-DMP 331i, DX10-333, DX10-333i, DX10-LMP 331, DX10-LMP 331i**

Ex marking:

- Ⓢ I M1 Ex ia I Ma Tamb = -20 ... +70 °C
- Ⓢ II 1G Ex ia IIC T4 Ga Tamb = -20 ... +70 °C
- Ⓢ II 1D Ex ia IIIC T110 °C Da Tamb = -20 ... +70 °C
- Ⓢ II 1G Ex ia IIC T5 Ga Tamb = -20 ... +50 °C
- Ⓢ II 1/2 D Ex ia/ib IIIC T100 °C Da/Db Tamb = -20 ... +40 °C

Ui = 28 V; Ii = 93 mA; Pi = 660 mW; Ci ≈ 37 nF + 0.22 nF \* L (with L = measured connecting cable length in meters)  
 Li ≈ 0 µH, Cgnd = 27 nF + 0.22 nF \* L (with L = measured connecting cable length in meters)

Ingress protection:  
 IP65 (for models with plastic connector)  
 IP68 (for models with fixed cable without connector)

Certificate Number:  
 ExNB 20 ATEX 0011 X

Assessment Report number and date:  
 24-0283/10 (2025.02.11)

#### 1.6.2. Specific conditions of use

##### DX4:

- The equipment designed with connector have to be installed in such way, that the Degree of protection IP20, respectively IP6X at explosive dust atmosphere, always will be kept.

- At pressure measuring devices with cable protection of corrugated pipe, the ground clamp at the coupling has to be connected with the equipotential bonding.

- The safety and assembly notes contained in the operating instructions have to be observed.

- At screwed probes with the marking category ½ equipment, the sensor diaphragm serves as partition wall and has to be protected against mechanical damages.

##### DX4B:

- For hydrostatic probes made of titanium impact and friction sparks are to be avoided by contact with other bodies and objects.

- The equipment designed with connector have to be installed in such a way that the degree of protection IP 20 is always kept.

- The safety and assembly instructions contained in the operating instruction and the ambient temperature range -25 ° ≤ Ta ≤ +65 °C have to be taken into account.

- The device may be operated in explosive atmospheres which requires equipment of Category 1 only when there are the atmospheric conditions (temperature of -20 °C to +60°C, pressure of 0.8 bar to 1.1 bar).

##### DX9:

- The equipment designed with connector has to be installed in such a way that the degree of protection IP 20 is always kept.

- The safety and assembly instructions contained in the operating instruction and the ambient temperature range depending on cable type -40°C/ -20°C ≤ Ta ≤ +70°C or at the types DX9-\*\*\* -40 °C / -20 °C ≤ Ta ≤ +65 °C have to be taken into account.

- The device may be operated in explosive atmospheres which require equipment of Category 1 only when there are atmospheric conditions (temperature of -20 °C to +60°C, pressure of 0.8 bar to 1.1 bar).

##### DX10:

- The device may be installed in environment where potentially explosive atmosphere with atmospheric (pabs=0.8bar ... 1.1bar) conditions may be present.

- For installation locations in Zone 0 with a risk of developing hazardous or damaging potential differences (susceptible to lightning or other surges) within Zone 0, a surge protection device capable of diverting a minimum peak discharge current of 10 kA (8/20 µs impulse according to IEC 60060-1 for 10 operations) shall be installed.

- The capacitance (22 nF / 100 meters) and inductivity of the connecting cable must be taken into account when commissioning probes with long cable.

- The ambient temperature range of the product depends on the type of explosion protection (see chapter 1.6.1).

### 1.7 Package contents

Please verify that all listed parts are undamaged in the delivery and check for consistency specified in your order:

- industrial pressure transmitter or screw-in transmitter
- for mechanical pressure ports DIN 3852: o-ring (pre-assembled)
- this operating manual
- with option SIL2 version: Functional Safety Manual, Functional Safety Data Sheet<sup>®</sup>, SIL Declaration of Conformity

### 2. Product identification

The device can be identified by its manufacturing label. It provides the most important data. By the ordering code the product can be clearly identified.

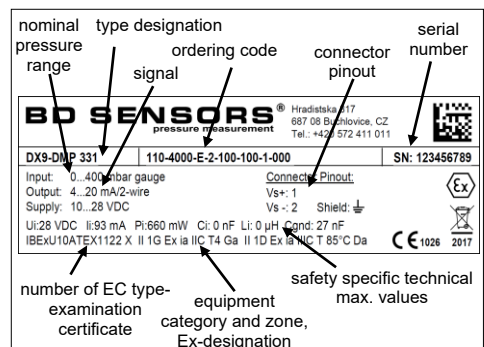

Fig1. Example of manufacturing label – for DX9

The manufacturing label must not be removed from the device!

### 3. Mechanical installation

#### 3.1 Mounting and safety instructions

⚠ WARNING! Install the device only when depressurized and currentless!

⚠ WARNING! This device may only be installed by qualified technical personnel who has read and understood the operating manual!

⚠ DANGER! Caused by the explosion hazard following instructions have to be complied with:

- The technical data listed in the EC type-examination certificate are. If the certificate is not available, please order or download it from our homepage: <http://www.bdsensors.com>
- Working on supplied (active) parts, except for intrinsically safe circuits, is principally prohibited during an explosion hazard.
- Make sure that an equipotential bonding is in place for the entire course of the line, both inside and outside the intrinsic area.
- In case of increased danger of lightning strike or damage by overvoltage, a stronger lightning protection should be planned.
- Observe the limiting values specified in the EC type-examination certificate. (Capacitance and inductance of the connection cable are not included in the values.)

- Make sure that the entire interconnection of intrinsically safe components remains intrinsically safe. The operator is responsible for the intrinsic safety of the overall system (installation of intrinsic parts).

- Do not mount the device in a pneumatic flow rate!
- Excessive dust deposits (over 5 mm) and a complete dust covering must be avoided!
- It is prohibited to open a device with field housings in the presence of explosion hazards.

⚠ Handle this high-sensitive electronic precision measuring device with care, both in packed and unpacked condition!

⚠ There are no modifications/changes to be made on the device.

⚠ Do not throw the package/device!

⚠ To avoid damaging the diaphragm, remove packaging and protective cap directly before starting assembly. The delivered protective cap has to be stored!

⚠ Place the protective cap on the pressure port again immediately after disassembling.

⚠ Handle the unprotected diaphragm very carefully - it is very sensitive and may be easily damaged.

⚠ Do not use any force when installing the device to prevent damage of the device and the plant!

⚠ For installations outdoor and in damp areas following these instructions:

- To prevent moisture admission in the plug the device should be installed electrically after mounting, at once. Otherwise a moisture admission has to be blocked e.g. by using a suitable protection cap. (The ingress protection in the data sheet is valid for the connected device.)
- Choose an assembly position, which allows the flow-off of splashed water and condensation. Avoid permanent fluid at sealing surfaces!
- When using a cable gland and outlet device, turn the outgoing cable downwards. If the cable has to be turned upwards, then point it downward so the moisture can drain.
- Install the device in such a way that it is protected from direct solar irradiation. Direct solar irradiation can lead to the permissible operating temperature being overstepped in the worst case. This is prohibited for applications in IS-areas!

⚠ For devices with gauge reference in the housing (small hole next to the electrical connection), install the device in such a way, that the gauge reference is protected from dirt and moisture. Should the device be exposed to fluid admission, the functionality will be blocked by the gauge reference. An exact measurement in this condition is not possible. Furthermore this can lead to damages on the device.

⚠ Take note that no inadmissibly high mechanical stresses occur at the pressure port as a result of the installation, since this may cause a shifting of the characteristic curve or to the damage. This is especially important for very small pressure ranges as well as for devices with a pressure port made of plastic.

⚠ In hydraulic systems, position the device in such a way that the pressure port points upward (ventilation).

⚠ Provide a cooling line when using the device in steam piping.

⚠ If the device is installed with the pressure connection up, it has to be made sure that no liquid drain off at the case. Humidity and dirt can block the relative cover in the case and it could lead to malfunctions through this. Dust and dirt must be removed from the edge of the thread connection of the electrical connection if required.

#### 3.2 Assembly and safety instructions - oxygen

⚠ DANGER! Explosion hazard, with devices for oxygen

- Make sure, your device has been ordered and delivered as a special version for oxygen applications. You can check the manufacturing label (see figure 1). If the ordering code ends with "007", then the device is suitable for oxygen applications.
- At time of delivery the device is packed into a plastic bag in order to prevent it from impurity. Please observe the indication label "Device for oxygen, unpack only directly before assembling". Also, avoid any skin contacts during unpacking and assembly, in order to prevent greasy residues on the device. During installation, the respective explosion protection regulations have to be met.
- Note the entire design requirements meet the standard demand of BAM (DIN 19247).
- For oxygen applications over 25 bar are recommended pressure transmitter without seals.
- Transmitters with o-rings of 70 EPDM 281: permissible maximum values: 15 bar/ 60° C and 10 bar/ 60 up to 90°C.
- Transmitters with o-rings of FKM Vi 567: permissible maximum values: 15 bar/ 60° C.

### 3.3 General installation steps

- Carefully remove the pressure measuring device from the package and dispose of the package properly.
- Go ahead as detailed in the specific instructions below.

### 3.4 Installation steps for DIN 3852

⚠ DO NOT USE ANY ADDITIONAL SEALING MATERIALS, LIKE YARN, HEMP OR TEFLON TAPE!

- Check to ensure the proper groove fitting of the o-ring and additionally to ensure no damage to the o-ring.
- Ensure that the sealing surface of the taking part is perfectly smooth and clean. (Rz 3.2)
- Screw the device into the corresponding thread by hand.
- If you have a device with a knurled ring, the transmitter has to be screwed in by hand only.
- Devices with a spanner flat have to be tightened with an open-end wrench (wrench size of steel: G1/4": approx. 5 Nm; G1/2": approx. 10 Nm; G3/4": approx. 15 Nm; G1": approx. 20 Nm; G1 1/2": approx. 25 Nm; wrench size of plastic: max. 3 Nm).
- **The indicated tightening torques must not be exceeded!**

### 3.5 Installation steps for EN 837

- Use a suitable seal, corresponding to the medium and the pressure input (e. g. a copper gasket).
- Ensure that the sealing surface of the taking part is perfectly smooth and clean. (Rz 6.3)
- Screw the device into the corresponding thread by hand.
- Tighten it with a wrench (for G1/4": approx. 20 Nm; for G1/2": approx. 50 Nm).
- **The indicated tightening torques must not be exceeded!**

### 3.6 Installation steps for NPT

- Use a suitable seal (e. g. a PTFE-strip).
- Screw the device into the corresponding thread by hand.
- Tighten it with a wrench (for 1/4" NPT: approx. 30 Nm; for 1/2" NPT: approx. 70 Nm).
- **The indicated tightening torques must not be exceeded!**

### 3.7 Installation steps for dairy pipe

- Check to ensure that the O-ring fits properly into the intended groove in the mounting part.
- Center the dairy pipe connection in the counterpart.
- Screw the cup nut onto the mounting part.
- Then tighten it with a hook wrench.

### 3.8 Installation steps for internal threads M20x1.5 and 9/16" UNF (for DMP 334)

- Screw the high pressure connection into the internal thread of the DMP 334 and tighten it properly with approx. 160 Nm.

⚠ DANGER! The high pressure tube seals metal-to-metal in the chamfer of the pressure port. No further seal is allowed with this high pressure connection. A wrong installation can cause enormous danger!

### 3.9 Installation steps for Clamp and Varivent<sup>®</sup>

- Use a suitable seal corresponding to the medium and the pressure input.
- Put the seal onto the corresponding mounting part.
- Center the Clamp or Varivent<sup>®</sup> connection on the fitting counterpart with seal.
- Then fit the device with a suitable fastening element (e. g. semi-ring or retractable ring clamp) according to the supplier's instructions.

### 3.10 Installation steps for connecting flanges

- Use a suitable seal corresponding to the medium and pressure input. (e. g. a fiber gasket).
- Put the seal between connecting flange and counter flange.
- Install the device with 4 resp. 8 screws (depending on flange version) on the counter flange.

### 4. Special regulations for IS-Areas

#### 4.1 Protection against electrostatic charge hazards

- Different types of the device partially consist of chargeable plastic components. These are, in particular, the carrying and connection cables, terminal boxes as well as housing enclosures. A potential electrostatic charge presents the danger of spark generation and ignition. An electrostatic charge must therefore be absolutely prevented.
- 📖 Generally, a shielded cable must be used.
  - 📖 Avoid friction on the plastic surfaces!
  - 📖 Do not clean the device dry! Use, for example, a damp cloth.

The following warning sign is, if applicable, attached to the transmitter. It points once more to the hazard of electrostatic charging.

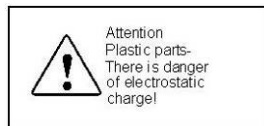

Fig. 2 warning sign

! The warning sign must not be removed from the device!

#### 4.2 Characteristic for TRIM TRIO® plug (code 5T2)

For devices with TRIM TRIO® plug (from SOURIAU) the application for intrinsically safe areas is restricted. The device can be identified by the code "5T2" in the segment "electrical connection" of the ordering code. The designation on the manufacturing label and purchase documents give information about the permissible area.

#### 4.3 Overvoltage protection

If the pressure transmitter is used as electrical equipment of category 1 G, then a suitable overvoltage protection device must be connected in series (attend the valid regulations for operating safety as well as EN60079-14).

#### 4.4 Schematic circuit

The operation of an intrinsically safe transmitter in intrinsic safe areas requires special care when selecting the necessary Zener barrier or transmitter repeater devices to allow the utilization of the device's properties to the full extent. The following diagram shows a typical arrangement of power supply, Zener barrier and transmitter.

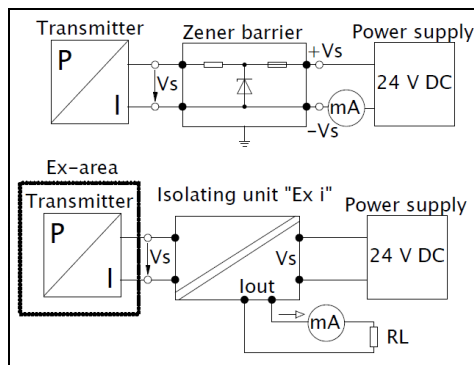

Fig. 3 circuit diagrams

! Please pay attention to item (17) of the type examination certificate, which stipulates special conditions for intrinsically safe operation.

#### 4.5 Exemplary circuit description

The supply voltage of e.g. 24 V<sub>DC</sub> provided by the power supply is led across the Zener barrier. The Zener barrier contains series resistances and breakdown diodes as protective components. Subsequently, the operating voltage is applied to the transmitter and, depending on the pressure, a particular signal current flows.

⚠ DANGER! When installing the intrinsically safe device as zone-0-equipment, the supplying must be carried out by a power supply which must be galvanically insulated and which must not be grounded.

#### 4.6 Functional selection criteria for Zener barriers and galvanic power supply

The minimum supply voltage V<sub>S min</sub> of the transmitter must not fall short since a correct function of the device can otherwise not be guaranteed. The minimum supply voltage has been defined in the respective product-specific data sheet under "Output signal / supply".

When using a galvanically insulated amplifier with linear bonding, note that the terminal voltage of the transmitter will decrease like it does with a Zener barrier. Furthermore, you have to note that the supply will additionally decrease with an optionally used signal amplifier.

#### 4.7 Test criteria for the selection of the Zener barrier

In order not to fall below V<sub>S min</sub>, it is important to verify which minimum supply voltage is available at full level control of the transmitter. The full level control, i.e. a maximum or nominal output signal (20 mA), can be reached by applying the maximum physical input signal (pressure).

The technical data of the barrier will usually provide the information needed for the selection of the Zener barrier. However, the value can also be calculated. If a maximum signal current of 0.02 A is assumed, then – according to Ohm's law – a particular voltage drop will result from the series resistance of the Zener barrier. This voltage drop is subtracted by the voltage of the power supply and as a result, the terminal voltage is obtained which is applied on the transmitter at full level control. If this voltage is smaller than the minimum supply voltage, another barrier or a higher supply voltage should be chosen.

⚠ When selecting the ballasts, the maximum operating conditions according to the EC type-examination certificate must be observed. When assessing these,

refer to their current data sheets to ensure that the entire interconnection of intrinsically safe components remains intrinsically safe.

#### 4.8 Calculation example for the selection of the Zener barrier

The nominal voltage of the power supply in front of the Zener barrier is 24 V<sub>DC</sub> ± 5 %. This results in:

$$\text{- greatest supply voltage: } V_{S \text{ up max}} = 24 \text{ V} \cdot 1.05 = 25.2 \text{ V}$$

$$\text{- smallest supply voltage: } V_{S \text{ up min}} = 24 \text{ V} \cdot 0.95 = 22.8 \text{ V}$$

The series resistance of the Zener barrier is listed with 295 ohm. The following values must still be calculated:

$$\text{- voltage drop at the barrier (with full conduction): } V_{ab \text{ barrier}} = 295 \Omega \cdot 0.02 \text{ A} = 5.9 \text{ V}$$

$$\text{- terminal voltage at the transmitter with Zener barrier: } V_{KI} = V_{S \text{ up min}} - V_{ab \text{ Barriere}} = 22.8 \text{ V} - 5.9 \text{ V} = 16.9 \text{ V}$$

$$\text{- minimum supply voltage of the transmitter, e. g. LMK 351 (according to data sheet): } V_{KI \text{ min}} = 12 \text{ V}_{DC} \text{ (corresponding to } V_{S \text{ min}})$$

Condition:

$$V_{KI} \geq V_{KI \text{ min}}$$

Result:

The terminal voltage of the transmitter with Zener barrier lies at 16.9 V and is therefore higher than the minimum supply voltage of the transmitter which lies at 12 V<sub>DC</sub>. This means, the Zener barrier has been selected correctly regarding the supply voltage.

⚠ Note that no line resistances have been listed in this calculation. However, these will lead to an additional voltage drop that must be taken into account.

#### 5. Electrical Installation

⚠ WARNING! Install the device only when depressurized and currentless!

⚠ DANGER! Danger of explosion when surpassing the maximum supply of 28 V<sub>DC</sub>!

⚠ The supply of the transmitter shall be double isolated from hazardous voltages.

⚠ The transmitter shall be supplied by Limited Energy Source (per UL 61010) or NEC Class 2 Power Source.

Establish the electrical connection of the device according to the technical data shown on the manufacturing label, the following table and the wiring diagram.

Pin configuration:

Electrical connections	ISO 4400	Binder 723 (5-pin)	M12x1 (4-pin)
Supply +	1	3	1
Supply -	2	4	2
Shield	ground pin	5	4

Electrical connections	Buccaneer (4-pin)	TRIM TRIO® (4-pin)
Supply +	1	1
Supply -	2	2
Shield	4	4

Electrical connections	field housing	cable colours (DIN 47100)
Supply +	IN +	wh (white)
Supply -	IN -	bn (brown)
Shield	⏏	gn/ye (green / yellow)

Wiring diagram:

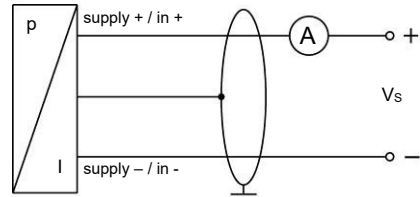

⚠ If the device is equipped with plug ISO 4400 or field housing, it must be ensured that the external diameter of the used cable is within the permissible clamping range:

- cable socket ISO 4400: Ø 4 ... 6 mm
- field housing code 850: Ø 2 ... 8 mm
- field housing code 880: Ø 5 ... 14 mm

Moreover you have to ensure that it lies in the cable gland firmly and cleftlessly!

! For the installation of a device with cable outlet following bending radiuses have to be complied with:

cable without ventilation tube:

static installation : 8-fold cable diameter

dynamic application: 12-fold cable diameter

cable with ventilation tube:

static installation : 10-fold cable diameter

dynamic application: 20-fold cable diameter

! Please note for devices with ISO 4400 or Buccaneer plug, that the cable socket has to be mounted properly to ensure the ingress protection mentioned in the data sheet. Please check if the delivered seal is placed between plug and cable socket. After connecting the cable fasten the cable socket on the device by using the screw.

! On devices with field housings, the terminal clamps are situated under the metal cap. To install the device electrically, the cap must be screwed off. Before the cover is screwed on again, the O-ring and the sealing surface on the housing have to be checked for damages and if necessary to be changed! Afterwards screw the metal cap on by hand and make sure that the field housing is firmly locked again.

! Prevent the damage or removal of the PTFE filter which is fixed over the end of the air tube on devices with cable outlet and integrated air tube.

! For a clear identification, the intrinsically safe cables are marked with light blue shrink tubing (over the cable insulation). If the cable has to be modified (e.g. shortened) and the marking at the cable end has been lost in the process, it must be restored (for example, by marking it again with light blue shrink tubing or an appropriate identification sign).

⚠ For the electrical connection a shielded and twisted multicore cable has to be used.

#### 6. Initial start-up

⚠ WARNING! Before start-up, the user has to check for proper installation and for any visible defects.

⚠ WARNING! The device can be started and operated by authorized personnel only, who have read and understood the operating manual!

⚠ WARNING! The device has to be used within the technical specifications, only! (compare the data in the data sheet and the EC type-examination certificate)

⚠ Devices with an accuracy of 0.1 % FSO have micro-controlled electronics for processing and improving the signal. Principally, the processing takes more time as for analogue sensors, which have only an amplifier. Due to this longer response time, the output signal follows the measured value discontinuously. For nearly stable measured values, this characteristic is secondary. Please compare the specification of the response time in the data sheet.

⚠ Intelligent devices with optional communication interfaces can also be configured by these electronics. Offset, span and damping are programmable within the limits given in the data sheet. For configuring the device, the programming kit CIS 510 consisting of Adapt 1, Windows® compatible programming software P-Scale 510, power supply and connecting cable is necessary. This can be ordered additionally from BD SENSORS.

#### 7. Placing out of service

⚠ WARNING! Disassemble the device only in current and pressure less condition! Check before disassembly, if it is necessary to drained off the media before dismantling!

⚠ WARNING! Depending on the medium, it may cause danger for the user. Comply therefore with adequate precautions for purification.

#### 8. Maintenance

⚠ DANGER! The operator is obligated to observe the information concerning operation and maintenance work on the warning signs possibly affixed to the device

⚠ In principle, in principle, this device is maintenance-free. If desired, the housing of the device can be cleaned using a damp cloth and non-aggressive cleaning solutions, in switched-off state.

⚠ With certain media, however, the diaphragm may be polluted or coated with deposit. It is recommended to define corresponding service intervals for control. After placing the device out of service correctly, the diaphragm can usually be cleaned carefully with a non-aggressive cleaning solution and a soft brush or sponge. If the diaphragm is calcified, it is recommended to send the device to BD SENSORS for decalcification. Please note the chapter "Service/Repair" below.

⚠ A false cleaning of the device can cause irreparable damages on the diaphragm. Therefore never use pointed objects or pressured air for cleaning the diaphragm.

#### 9. Service / Repair

##### 9.1 Recalibration

During the life-time of a transmitter, the value of offset and span may shift. As a consequence, a deviating signal value in reference to the nominal pressure range starting point or end point may be transmitted. If one of these two phenomena occurs after prolonged use, a recalibration is recommended to ensure furthermore high accuracy.

##### 9.2 Return

Upon every return of the device, no matter if for recalibration, decalcification, modifications or repair, it is necessary to contact us to guarantee a quick execution of your request. Please inform us by sending an email to: sale@bdsensors.cz. Include the number of devices sent and request a RMA. Afterwards clean the device, pack it shatterproof and send it to BD SENSORS indicating the RMA.

#### 10. Declaration of conformity / CE

The delivered device fulfils all legal requirements. The applied directives, harmonised standards and documents are listed in the EC declaration of conformity, which is available online at: <http://www.bdsensors.com/>. Additionally, the operational safety is confirmed by the CE sign on the manufacturing label.

#### 11. Warranty conditions

The warranty conditions are subject to the legal warranty period of 24 months from the date of delivery. In case of improper use, modifications of or damages to the device, we do not accept warranty claims. Damaged diaphragms will also not be accepted. Furthermore, defects due to normal wear are not subject to warranty services.

#### 12. Error handling

Malfunction	Possible cause	Error detection / corrective
no output signal	wrong connected	inspect the connection
	line break	inspect all line connections necessary to supply the device (including the connector plugs)
	defective amperemeter (signal input)	inspect the amperemeter (fine-wire fuse) or the analogue input of the PLC
analogue output signal too low	load resistance too high	verify the value of the load resistance
	supply voltage too low defective energy supply	verify the output voltage of the power supply inspect the power supply and the applied supply voltage at the device
small shift of output signal	diaphragm is highly contaminated	careful cleaning with non-aggressive cleaning solution and a soft brush or sponge; incorrect cleaning can cause irreparable damages on diaphragm or seals
	diaphragm is calcified or coated with deposit	if possible, it is recommended to send the device to BD SENSORS for decalcification or cleaning
large shift of output signal	diaphragm is damaged (caused by overpressure or manually)	check the diaphragm; if it is damaged, please send the device to BD SENSORS for repair
wrong or no output signal	manually, thermal or chemically damaged cable	check the cable; a possible consequence of a damaged cable is pitting corrosion on the stainless steel housing; if you determine this please return the device to BD SENSORS for repair

If you detect an error, please try to eliminate it by using this table or send the device to our service address for repair.

⚠ DANGER! Working on supplied (active) parts, except for intrinsically safe circuits, is principally prohibited during an explosion hazard. Additionally, the operator is obligated to observe the information concerning operation and maintenance work on the warning signs possibly affixed to the device.

! Improper action and opening can damage the device. Therefore repairs on the device may only be executed by the manufacturer!

#### 13. Disposal

The device has to be disposed of according to the European Directives 2012/19/EU and 16/2022 coll. (on waste electrical and electronic equipment). It is prohibited to place electrical and electronic equipment in domestic refuse!



⚠ WARNING! Depending on the used medium, deposit on the device may cause danger for the user and the environment. Comply with adequate precautions for purification and dispose of it properly.

#### 14. Separate Pt100 sensor

If the transmitter contains the separate Pt100 temperature sensor, the following ratings of the intrinsic safety Ex ia IIC must be taken into account:

U<sub>i</sub> 30 V DC  
I<sub>i</sub> 54 mA  
P<sub>i</sub> 405 mW

Effective inner capacity C<sub>i</sub> negligible

Effective inner inductivity L<sub>i</sub> negligible

plus cable inductivities 1.5 µH/m and cable capacities 220 pF/m (for cable by factory)